

High Power Transistor Module Thermal Testing

There are two versions of high power transistor module circuits. One version has direct external connection to each transistor within the module without any parasitic circuit elements that limit the activation of the transistor. Some connections may be shared – like the collector contacts, for example – but each transistor can be operated on its own without any impact from the other transistors in the module. An example of this version is shown in Figure 1A. A module with some protective components included, such as Figure 1B, may not allow direct access to the transistor attributes that are required in thermal measurements. The other version, shown in Figure 2, has driver circuitry built-in to provide the module with more functionality and reliability; this version typically does not provide access to all the transistor leads. Both of these versions apply to any transistor (BJT, MOSFET, or IGBT) module.

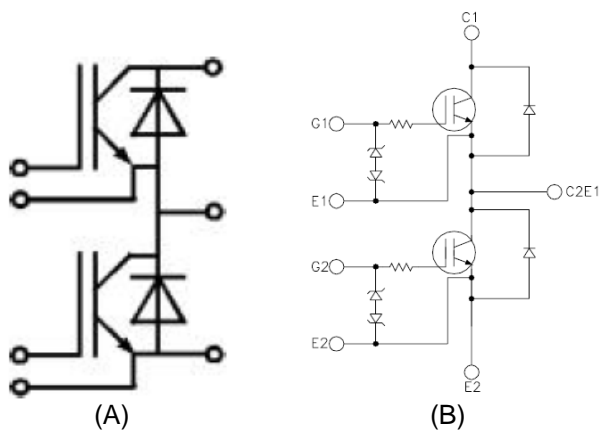

Figure 1

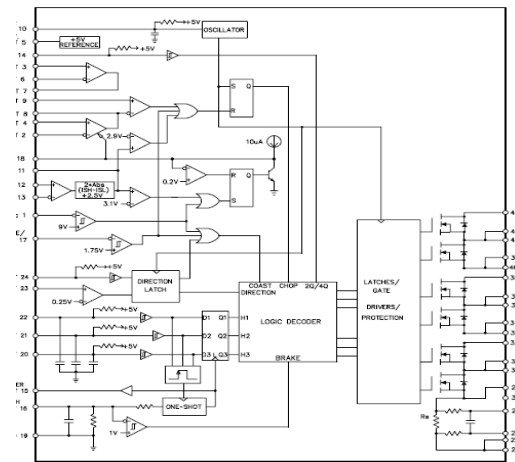

Figure 2

The first version allows for thermal measurements on each individual device. Because the individual transistor leads are externally accessible, each transistor can be thermally measured using standard test methods, such as the ones defined by Mil-Std-750 Methods 3131, 3161, and 3103, for Bipolar Junction Transistors (BJTs), Metal-Oxide-Semiconductor Field Effect Transistors (MOSFETs) and Insulated-Gate Bipolar Transistors (IGBTs), respectively. [Note: Copies of these test methods are available at http://www.thermengr.net/html/military_stds.html.]

Thermal measurements on the second version is much more difficult and, in fact, may be impossible on finished (i.e., fully encapsulated) modules. In this case, thermal measurements can only be made during the module assembly process before the electrical connections to the driver and/or protection circuitry is put into place. This requires either using electrical probes to make direct contact to the transistor die bonding pads or after electrical connection (i.e., wire bonds) between the transistor and isolated pads in the module but before the driver circuitry is connected up.

High Power Transistor Module Thermal Testing (cont'd)

Implementing thermal measurements at this point in the assembly process offers several benefits. First, a heating pulse, long enough for the heat to propagate through the die attached region and into the package but not through the package, is relatively short in time – typically 30ms to 200ms – and provides a quick and easy way to quantitatively determine die attachment integrity from a thermal viewpoint. Second, because the heating pulse is specifically chosen not to heat the package, the package environment does not affect the thermal measurement. Third, the measurement can be implemented right after the die is attached to the package, thus providing rapid feedback on the die attachment process. Units demonstrating poor die attachment integrity can either be reworked or scrapped before putting any more value added into the potentially defective units.

Another issue to consider in thermal measurements of transistor modules deals with dissipating power in the device-under-test (DUT). Most transistor modules are intended for *switch mode* operation in which the device is either full “on” – i.e., low resistance of low V_{CEsat} , or “off” – i.e., very high voltage at very low current. Neither of these states is conducive to thermal measurements. The “on” state requires very high current to dissipate suitable heating power and, because the DUT is very heavily saturated, the switching times are not very fast, making accurate thermal measurements difficult. In the “off” state, the transistor can not dissipate enough power to make meaningful thermal measurements. Thus, even though the transistor can handle very high current and very high voltage in either mode, it can not handle them simultaneously. The DUT must operate in the *linear mode* within its Safer Operating Area (SOA). [See TB-13 at http://www.thermengr.net/html/tech_briefs.html for a description of SOA.]

The need for transistor operation in the SOA-limited *linear mode* for thermal measurements usually can be satisfied with thermal test equipment that can provide Heating Voltages (V_H) in the 5V to 20V range and Heating Current (I_H) in the 10A to 20V range. Both the TTS-2500 and the TTS-2550 thermal test systems meet these requirements. [More details about these systems can be found at http://www.thermengr.net/html/test_systems.html.]